

AKO-575xxx**V3** Gas transmitter

User manual



Index	Page
1.- Versions and references.....	3
2.- Warning.....	3
3.- Equipment description.....	4
4.- Installation.....	6
5.- Operation.....	10
6.- Configuration.....	14
7.- Connectivity.....	17
8.- Maintenance.....	18
9.- Installation of AKO-58110 calibration kit.....	18
10.- Operation test (Bump Test).....	19
11.- Verification of accuracy (Calibration).....	20
12.- Reset to zero.....	21
13.- Full scale setting.....	22
14.- Technical specifications.....	23
15.- Accessories.....	25



Caution symbol



Information symbol



Caution symbol, risk of electric shock

AKO Electromecánica thanks and congratulates you for purchasing our product, in whose development and manufacture the most innovative technology has been used, as well as strict production and quality control processes.

Our commitment to satisfy our customers and our continuous efforts to improve every day can be seen in the various quality certifications we have obtained.

This is a high performance, high technology product. The operation and final performance of the equipment depend on proper planning, installation, configuration and commissioning. Read this manual carefully before installation, and always follow its instructions.

Only qualified personnel should install or perform technical assistance on this product.

This product is designed to be used in the applications described in the product manual. AKO Electromecánica gives no guarantee of its operation in any use not foreseen in the manual, and is not responsible for any damage resulting from improper use, configuration, installation or commissioning.

It is the responsibility of the installer and the customer to comply with and ensure others comply with all regulations applicable to installations incorporating our products. AKO Electromecánica is not responsible for any damage caused by non-compliance with regulations. Follow strictly the instructions given in this manual.

To maximise the service life of our equipment, these recommendations should be followed:

Do not expose electronic equipment to dust, dirt, water, rain, humidity, high temperatures, chemicals or corrosive substances of any sort.

Do not submit the equipment to blows or vibrations nor try to manipulate it differently from shown in the manual.

Never exceed the specifications and limitations indicated in the manual.

Always respect the specified ambient working and storage conditions.

During and after installation, avoid leaving loose, broken, unprotected or damaged wiring, since they might constitute a risk for the equipment and its users.

AKO Electromecánica reserves the right to make any non-metrology modification to the documentation or the equipment without previous notice.

1.- Versions and references

MODEL	DESCRIPTION	POWER SUPPLY
AKO-575400	Universal gas transmitter for R-23 / R-32 / R-125 / R-134a / R-404A / R-407A / R-407F / R-410A / R-448A / R-449A / R-452A / R-455A / R-513A *(R-450A / R-442A / R-454A / R-454c / R-1234yf / R-1234ze / R-515b)	12-30 Vdc
AKO-575400N	Universal gas transmitter with comunicación NBloT R-23 / R-32 / R-125 / R-134a / R-404A / R-407A / R-407F / R-410A / R-448A / R-449A / R-452A / R-455A / R-513A *(R-450A / R-442A / R-454A / R-454c / R-1234yf / R-1234ze / R-515b)	
AKO-575400NE	Universal gas transmitter for with NBloT communication and external antenna for R-23 / R-32 / R-125 / R-134a / R-404A / R-407A / R-407F / R-410A / R-448A / R-449A / R-452A / R-455A / R-513A *(R-450A / R-442A / R-454A / R-454c / R-1234yf / R-1234ze / R-515b)	
AKO-575744	R-744 (CO ₂) gas transmitter	
AKO-575744N	R-744 (Co ₂) gas transmitter with NBloT communication	
AKO-575744NE	R-744 (Co ₂) gas transmitter with NBloT communication and external antenna	
AKO-58500	CAMM module	-
AKO-58120	Protector for push-button/detector	-
AKO-58110	Calibration tool	-



AKO-575xxx



AKO-58500

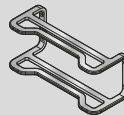

AKO-58120

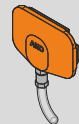

AKO-58110



2.- Cautions







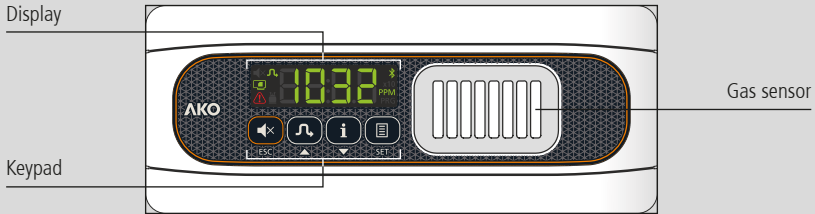

- Transmitters should be installed in a place protected from vibrations, water and corrosive gases, where the ambient temperature does not exceed the value indicated in the technical data.
- The transmitter is not suitable for areas classified as potentially explosive.
- Transmitters/detectors supervise a point and not an area. If the gas leak does not reach the sensor, or the level of concentration in that point does not reach the foreseen values according to the type of gas no alarm will be activated. If perimeter supervision is required, several sensors should be installed around that area.

* Gases in brackets are detected early, albeit without a specific measurement set parameter. Further details can be found in the table page 20.

3.- Equipment description



Indicadores







-  Gas alarm on mute
-  **Fixed:** Set Hold mode activated
Flashing: Maintenance mode activated
-  **Fixed:** CAMM module in operation*
Flashing: Malfunction in CAMM module*
-  **Fixed:** Gas pre-alarm activated.
Flashing: Gas alarm activated.
-  The display shows the type of gas detected.
-  Bluetooth activated (CAMM module only)*
-  **x10** The value displayed should be multiplied by 10.
-  **PPM** The display shows the current gas concentration in ppm (parts per million).
-  **PRG** Unit in programming mode

Only NB-IoT devices

-  **Constant:** Connected to the NB-IoT network (Narrow band)
Switched off: NOT connected to the NB-IoT network or expired license.

*Not available in NB-IoT devices

Keypad

-  If the gas Pre-Alarm or Alarm sounds, pressing once will mute the alarm tone (See parameter **b03**). In the programming menu, it exits the parameter without saving changes, returns to previous level or exits programming.
-  Pressing for 3 seconds activates or deactivates Set Hold mode (see page 11).
 Pressing for 6 seconds activates or deactivates maintenance mode (see page 11).
In the programming menu it allows scrolling around the different levels, or during the setting of a parameter, changing its value.
-  Pressing once (< 1 second) will show the type of gas detected, the date and time in sequential order.
 Pressing for 3 seconds displays the Pre-Alarm and Alarm levels that have been configured.
In the programming menu it allows scrolling around the different levels, or during the setting of a parameter, changing its value.
-  Pressing for 3 seconds accesses the configuration of alarm levels (see page 14).
 Pressing it for 6 seconds accesses the advanced programming menu (see page 14).
In the programming menu, it accesses the level shown on the display or, during the setting of a parameter, accepts the new value.

Only NB-IoT devices

-  Forces data transfer to the cloud via NB-IoT connectivity.

Messages



Gas Pre-Alarm activated. Flashing together with the gas concentration (see page 12)



Gas alarm activated. Flashing together with the gas concentration (see page 12)



Initialisation process of the gas sensor. This process may last for up to 3 minutes.



Error or malfunction of the sensor. Deactivate the power supply and activate it again. If after a few seconds the error persists, please contact your technical support centre.



Request for protection code (See page 21 and page 22)



SA reading of greater than 300 PPM has been detected during the reset to zero process (see page 21)



The temperature of the sensor has experienced a variation of greater than 5 °C during the calibration or reset to zero process (See page 21 and page 22)



The maximum time has been exceeded without the reading stabilising during the calibration process (15 min) or reset to zero process (5 min) (See page 21 and page 22)



The calibration or reset to zero process has been completed successfully (See page 21 and page 22)



The sensor has reached its maximum working temperature.



The sensor has reached its minimum working temperature.



Calibrating or resetting to zero (See page 21 and page 22)

4.- Installation



CAUTIONS

-Transmitters/detectors supervise a point and not an area. If the gas leak does not reach the sensor, or the level of concentration in that point does not reach the foreseen values according to the type of gas (see page 3) no alarm will be activated. If perimeter supervision is required, several sensors should be installed around that area.

-The transmitter/detector should be installed in a place protected from vibrations, water and corrosive gases, where the ambient temperature does not exceed the value indicated in the technical data.

-Gas transmitters/detectors are not suitable for areas classified as potentially explosive.

Working conditions:

-Avoid handling refrigerant gases near the sensor. If this is unavoidable, use Set Hold or Maintenance mode (see page 11)

-If the equipment is used in a manner not specified by the manufacturer, the protection provided by the equipment may be impaired.

-Do not paint the sensor or place it near solvents or paints.

-Exposure to acetone vapours may generate false alarms.

-The sensor should be installed away from:

- Smoke outlets located in confined spaces or from engines, generators or motorised machinery (fork-lift trucks, etc.).
- Particularly damp areas or areas with strong ventilation.

Only NB-IoT devices

Before activating the device, make sure that there is enough reception at the installation location. **Activated devices may not be returned.**

Avoid installing the device on metal walls or near devices that may produce radio emissions.

This device must be installed in a location where a minimum distance of 20 cm to the human body can be guaranteed, in order to ensure compliance with standards on human exposure to electromagnetic fields.

The **AKO-575400NE, AKO-575744NE devices must NEVER** be operating without having installed the external antenna. This device can be fitted with any antenna provided it has a gain of less than 9.2 dBi and there is a minimum distance of more than 20 cm between it and any person or animal.



The detector should usually be installed in an area where gas may concentrate, near places where gas leaks could start:

- **In compressor/cooling generator rooms:** near to compressors and pressure accumulation tanks. In this environment, the elements most susceptible to refrigerant leaks are valves, pressure sensors, flanges and soldering. In this environment (compressor/cooling generator rooms) with little ventilation there are two practical strategies for installation:
- **Point detection:** Transmitters are placed close to places identified as being critical/susceptible to leaks.
- **Perimeter detection:** Transmitters surround the service area to ensure that a potential leak in the system is detected by one of the transmitters.
- **Refrigerated spaces (chambers, islands, cabinets, display cases, etc.):** It is advisable to use the sensor in low-lying areas close to the evaporator. However, it is important to avoid areas with high air velocity such as the input/output of air in the evaporator and areas close to doors with heavy footfall.

Accessible installation is important for carrying out maintenance tasks. It is also advisable to place the sensor away from transit areas or areas where it could be accidentally knocked.

The gases currently used in industrial refrigeration, for which this transmitter has been designed, are heavier than air. They are therefore always concentrated in the lowest part of the refrigerated room or space. Please take this into consideration when choosing the installation site. It is advisable to leave a distance of around 50 cm free.

Assembly

- Remove the bezels (1) from the unit.
- Loosen the screws (2) by turning them a 1/4 turn and open the cover (3).
- Drill the holes needed for the cable entry glands using the pre-stamped centres on the sides of the housing for guidance. Fix the glands onto the device (4).
- Make the 2 holes in the wall using template included.
- Fix the unit to the wall using the screws and plugs supplied (5). If the wall is made of sheet metal (prefabricated cold room stores), use only the screws provided without plugs.
- Insert the cables into the glands. Wire the unit following the diagram on page 8.
- Close the cover (3), insert and tighten the screws (2) and replace the bezels (1).

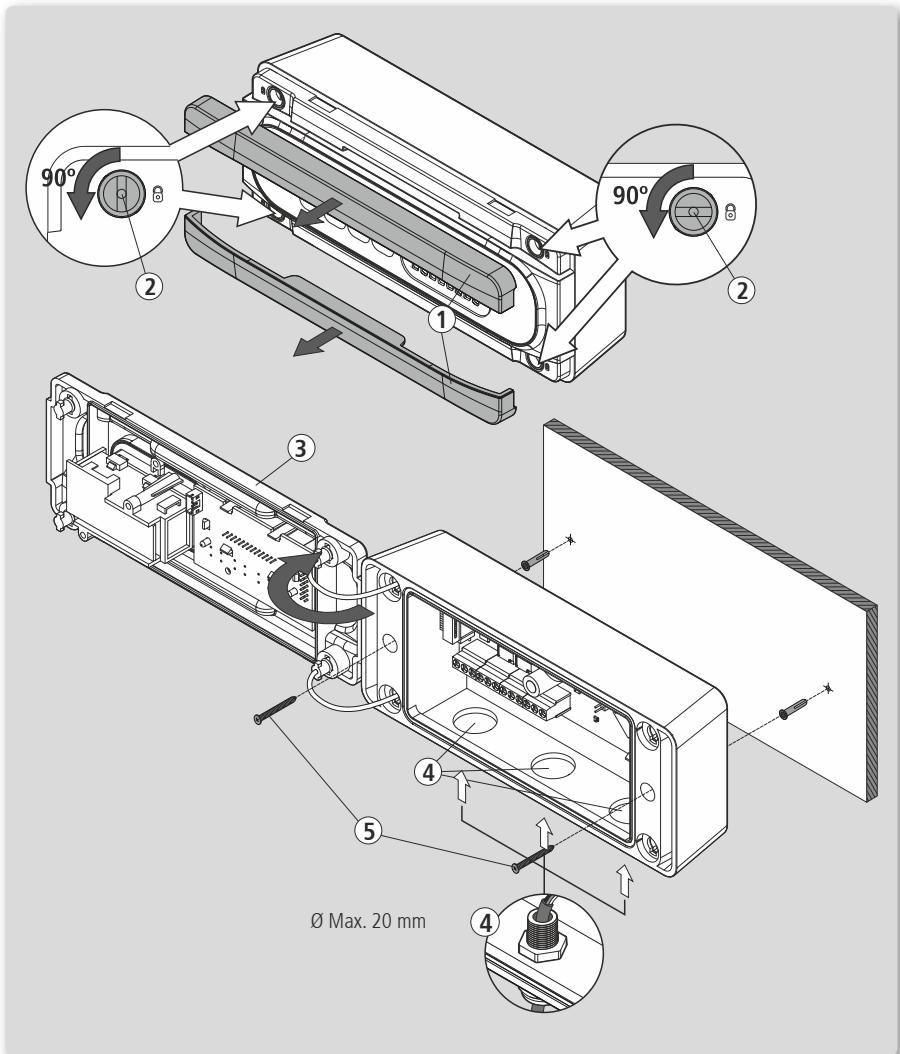

 **Wiring**

The wiring between the transmitter and the station must NEVER be installed in a conduit together with power, control or power supply cables.

Always disconnect the power supply to do the wiring.

Cables for wiring the relay contact should have an adequate section depending on the unit to be connected. Use copper conductors only.

Certain international standards maintain that the power supply of the alarm should originate from a different circuit to that used by the refrigeration and ventilation system. **Please ensure that you comply with current local regulations.**

Only for independent operation

Use only a 12–30 VDC power supply connected through the designated connector, and meet the following requirements:

- Limited Energy Circuit in accordance with UL/CSA 61010-1; or
- Limited Power Source (LPS) in accordance with UL/CSA 60950-1 or EN 62368-1, Annex Q; or
- Class 2 supply source which complies with the National Electrical Code (NEC), NFPA 70, Clause 725.12, and the Canadian Electrical Code (CEC), Part I, C22.1.

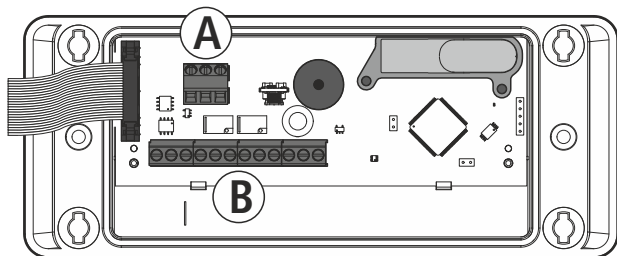
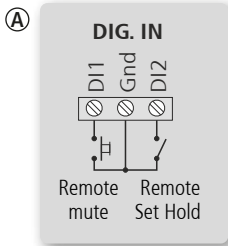

Connection to alarm station

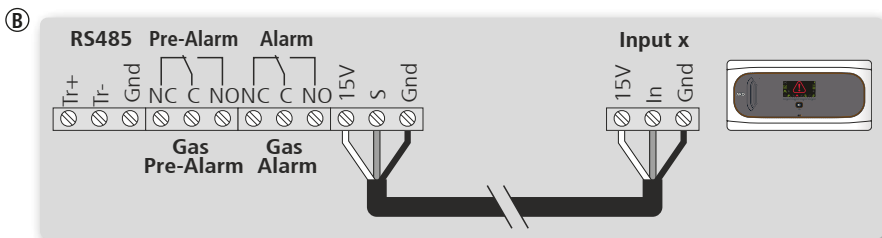

Independent operation

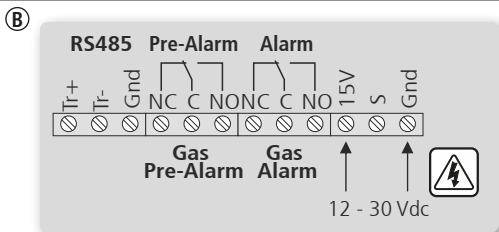

Only NB-IoT devices

Signing up to akonet.cloud

In order for the transmitter to be able to send operating data to akonet.cloud, it must be registered. To do this, go to <https://akonet.cloud> (requires registration), click on "Ad new device"  and continue with one of these two methods:

A.-Enter the serial number (S/N) and validation code / IMEI that appear on the tag and press "Search".

B.-Capture the **QR** code that appears on the tag using the  option (requires having a camera on your PC, tablet or mobile phone).



These data are found on the tag on the right hand side of the transmitter. More information can be found in the akonet.cloud user guide at: "<https://enhelppakonet.ako.com>" To access akonet.cloud, enter this address in your browser (the use of Google Chrome is recommended): <https://akonet.cloud>.

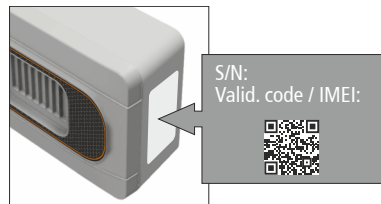

Before activating the device, make sure that there is enough reception at the installation location. **Activated devices may not be returned.**

Forcing transmission

When the steps of the configuration wizard and the registration process are completed in akonet.cloud, you must force a first transmission to verify the level of reception:

- Press and hold the **ESC** and **SET** keys for 3 seconds.
- After a moment, the display shows the quality of the NBloT signal received:

Low quality



Medium quality



High quality



Communication error



The transmitter does not start transmitting data to akonet.cloud until the first transmission is forced.



It is advisable to reset to zero on start-up. See the different methods on page 21.

Operating modes

Connection to alarm station (o00=0)

Choose this option if the transmitter is connected to a compatible alarm station.

In this mode, the acoustic alarm is disabled and the output is configured to communicate with the station.

Compatible stations: **AKO-558241** **AKO-55724**
 AKO-558242 **AKO-55624**

Independent operation (o00=1)

Choose this option if you want the transmitter to function independently.

5.- Operation

Without alarms

The display shows the current gas concentration in ppm (Parts per million) (If **b01=0**) or the type of gas to be measured (**b01=1**).

Parameter **b02** allows you to fix a value below which the display will always show zero.



Only NB-IoT devices

The transmitter regularly sends to the cloud (akonet.cloud) the gas concentration data and other operation information at specific intervals based on the akonet.cloud parameter "continual log interval".

Any change in the configuration of the transmitter or its operation (mode changes, errors, etc.) are sent to the cloud instantly.



Concentrations measuring under 75 PPM can be due to measuring or calibration errors. For greater precision, it is recommendable to carry out a calibration once installation of the transmitter has been completed.



Sensor error/malfunction

The station emits 3 short beeps every two minutes and the input indicator affected flashes red. Deactivate the power supply and activate it again. If after a few seconds the error persists, please contact your technical support centre.



MUTE function

Mutes the sound and/or deactivates the relays of gas pre-alarms and alarms according to the configuration of parameter **b03**. This does not affect the operation of the indicators.

To activate this function, press the  key at any time when a pre-alarm or alarm is activated. The display shows the  indicator of alarm on mute.

You may also activate this function remotely using digital input 1 (DI1) if required.



This function will automatically cancel each type an alarm changes status (from pre-alarm to alarm, from alarm to pre-alarm).



Set Hold mode

Prevents false alarms when charging or cleaning the chambers.

While this mode is activated, pre-alarms will not signal and alarms will signal as pre-alarms when faced with all effects (sound, relay activation and signalling).

To activate/deactivate this mode, press the  key for 3 seconds. The display will show the  indicator.

You may also activate/deactivate this function remotely using digital input 2 (DI2) if required.

This mode will remain active for a maximum of 5 hours, then will deactivate automatically.



If this mode is activated using the  key, it can only be deactivated using the same key. This is also true when activating the mode using digital input 2.

Maintenance mode

Disables gas pre-alarms and alarms for 1 hour for maintenance tasks.

While this mode is activated, no gas pre-alarm or alarm will sound.

To activate/deactivate this mode, press the  key for 6 seconds. The  indicator will flash.



If there is a sudden increase in temperature near the transmitter, either in the cold room loading process, or because the door has been accidentally left open, there is a risk of condensation occurring inside the transmitter. In these conditions, the maintenance mode temporarily activates to avoid false alarms. The transmitter returns to normal operation after 3 to 15 minutes.

In these cases, the maintenance mode cannot be manually deactivated.



The maintenance mode automatically activates for 5 minutes to prevent activation of alarms after calibration has finished.

In this case, the maintenance mode cannot be manually deactivated.

Access code (Password)

Restricts access to the transmitter's functions to authorised personnel. Parameter **b11** defines the code and parameter **b10** defines the function of the code:

b10=0 Disabled

b10=1 Blocks access to programming (Parameters) but enables the use of the rapid keypad functions

b10=2 Blocks any keypad function

Alarms

The transmitter emits an acoustic alarm, the alarm indicator flashes and activates the relays when certain gas concentration levels are exceeded. If the transmitter is connected to a station, the station will emit the acoustic alarm. The relays will be activated in both devices.

There are two alarm levels depending on the concentration of gas detected: Pre-Alarm and Alarm. Both are factory preset but can be modified by means of parameters AL3 and AL6. These values comply with domestic and international regulations (RSIF, EN 378 and EN 14624). However, please ensure that these values comply with current local regulations. In order to modify these values, parameter **AL1** should be configured to 1.

Only NB-IoT devices

Activations and deactivations of pre-alarms and alarms are sent to the cloud instantly.

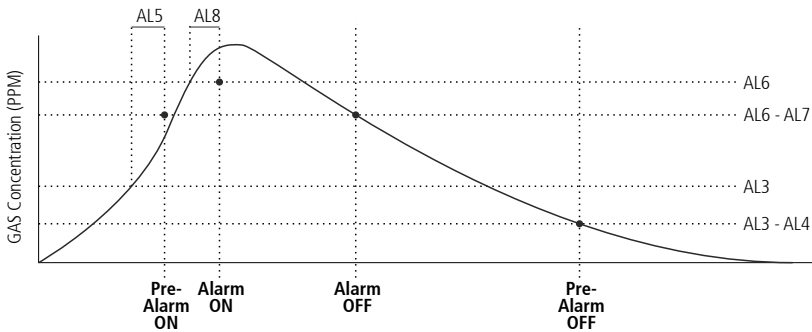

Pre-Alarm

Warns the user that the gas concentration is increasing.

The Pre-Alarm relay can be connected to air extraction systems to disregard possible temporary leaks or false detections caused by external agents.

The activation level of the Pre-Alarm is determined by parameter **AL3** and is deactivated when it drops below **AL3** minus differential **AL4**.

Parameter **AL5** can be used to apply a delay period between **AL3** being exceeded and the Pre-Alarm being set off. Parameter **AL2** can be used to disable the Pre-Alarm. Before doing this, ensure that relevant regulations permit this action.



Alarm

Warns the user that the gas concentration has reached high levels.

It is advisable to use the alarm relay to halt installation by connecting it to the security chain.

The activation level of the Pre-Alarm is determined by parameter **AL6** and is deactivated when it drops below **AL6** minus differential **AL7**.

Parameter **AL8** can be used to apply a delay period between **AL6** being exceeded and the Alarm being set off.



Digital inputs

The transmitter has 2 digital inputs which are used to remotely activate the Mute (DI1) and Set Hold (DI2) functions. The wiring of both is explained on page 8.

Pressing once activates or deactivates each function. The polarity of the inputs is configured using parameters **I11** (DI1) and **I21** (DI2).

Statuses

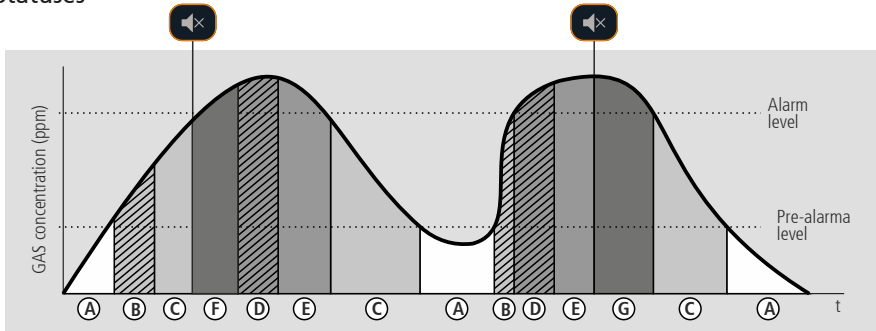

STATUS	TRANSMITTER					RELAYS	
					Pre-alarm	Alarm	
Ⓐ Without alarm		83 ppm		OFF			
Ⓑ Delayed pre-alarm		536 ppm		OFF			
Ⓒ Pre-alarm		PAL		Sonido intermitente			
Ⓓ Delayed alarma		PAL		Sonido intermitente			
Ⓔ Alarm		AL		Sonido bitonal			
Ⓕ Muted pre-alarm		PAL		OFF	Depending on b03	Depending on b03	
Ⓖ Muted alarm		AL		OFF	Depending on b03	Depending on b03	
Sensor error		ES		3 short tones every 2 minutes			
Without power supply		83 ppm		OFF			

6.- Configuration

Direct access to alarm levels

To configure the Pre-Alarm and Alarm levels, hold the **SET** key down for 3 seconds. (Only if **AL1=1**)

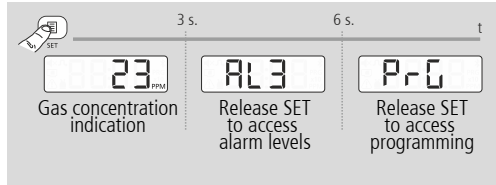

Programming menu

Use the programming menu to configure the various parameters in order to adapt the transmitter's operation to the requirements of its installation. Press the **SET** key for 6 seconds to access the programming menu.



IMPORTANT: If the function of the password has been configured as a keypad block (**b10=2**), or as an access block to parameters (**b10=1**), you will be requested to enter the access code programmed in **b11** when attempting to access either of the two functions. If the password entered is not correct, the unit will go back to showing the gas concentration. (see page 11).

Operation of the keypad in programming



It exits the parameter without saving changes, returns to previous level, or exits programming.



It allows you to scroll through the different levels, or when setting a parameter, to change its value.



It allows you to scroll through the different levels, or when setting a parameter, to change its value.



It accesses the level shown on the display or, when setting a parameter, it accepts the new value.

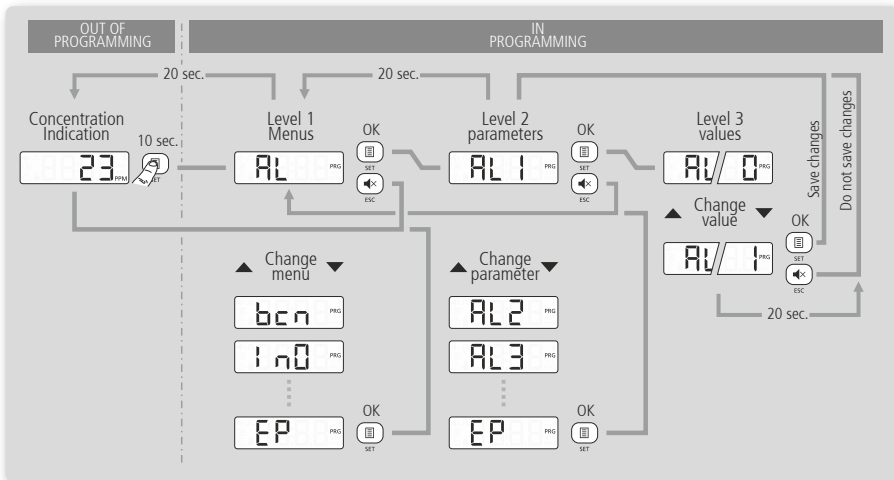

Only NB-IoT devices

Configuration can also be done through akonet.cloud, for more information go to: <https://enhelapakonet.ako.com>

Parameters

The unit operating parameters are organised in different groups or families according to their function.

The **Def.** column indicates the default parameters set in the factory.

Level 1	Level 2	CONFIGURACIÓN DE ALARMAS					
		Description	Values	Min.	Def.	Max.	
RL	RL1	Alarm levels: 0: According to regulation 1: Set by user		0	1	1	
	RL2	Pre-Alarm 0: Disabled 1: Enabled		0	1	1	
	RL3	Pre-Alarm Level *	AKO-575744 / 575744N / 575744NE Other models	PPM	B02 ó AL4+1	4000 500	AL6
	RL4	Pre-Alarm Differential		PPM	10	100	200
	RL5	Pre-Alarm Delay (0: Disabled)		min.	0	0	15
	RL6	Alarm Level *	AKO-575744 / 575744N / 575744NE Other models	PPM	AL3	8000 1000	10000 2000
	RL7	Alarm Differential		PPM	10	100	200
	RL8	Alarm Delay (0: Disabled)		min.	0	0	15
	EP	Exit to level 1					

Level 1	Level 2	BASIC CONFIGURATION				
		Description	Values	Min.	Def.	Max.
bcn	Gc1	Type of gas to be measured (Reading only)		-	-	-
	Gc2	Gas to be measured with the Universal sensor (Only if Gc1=brd1) ALL; 125; 134A; 404A; 407A; 407F; 410A; 448A; 449A; 513A; 452A; 32; 23; 455A		-	ALL	-
	b01	Display 0: Measurement in PPM; 1: Type of gas to be measured		0	0	1
	b02	Minimum value to be shown on the display (Lower values are shown as 0) Does not affect the values shown by communication (AKONet or CAMM module)	PPM	0	0	250
	b03	Function of the mute key (Applicable to Alarm and Pre-Alarm) 0: Disabled 1: Deactivate acoustic alarm 2: Deactivate relay 3: Deactivate both		0	1	3
	b04	Acoustic alarm 0: Disabled; 1: Enabled		0	1	1
	b10	Access code (password) function 0: Disabled; 1: Block access to parameters 2: Block keypad		0	0	2
	b11	Access code (password)		0	0	99
	b20	MODBUS address		1	***	247
	b21	MODBUS speed 0: 9600 bps 1: 19200 bps 2: 38400 bps 3: 57600 bps		0	0	3
	b22	STOP bits for MODBUS communication 1: 1 STOP bit, 2: 2 STOP bits		1	1	2
	b23	MODBUS communication parity 0: No parity, 1: Odd, 2: Even		0	0	2
	EP	Exit to level 1				

* In order to modify these levels, parameter **AL1** should be configured to 1.

*** The MODBUS address will be shown on the transmitter label by default.

Level 1	Level 2	INPUT AND OUTPUT CONFIGURATION				
		Description	Values	Min.	Def.	Max.
h0	i00	Reset to zero of the sensor (Calibration only, see page 21)* 0: Disabled; 1: Reset to zero activated		0	-	1
	i01	Setting the sensor (Calibration only, see page 22)* 0: Disabled; 1: Setting activated		0	-	1
	i11	Polarity of digital input 1 (Remote Mute) 0: Activates on opening contact; 1: Activates on closing contact		0	0	1
	i21	Polarity of digital input 2 (Remote Set Hold) 0: Activates on opening contact; 1: Activates on closing contact		0	0	1
	o00	Type of output 4/20 mA 0: Calibrated for alarm station; 1: Linear		0	0	1
	EP	Exit to level 1				

Level 1	Level 2	INFORMATION (Reading only)				
		Description	Values	Min.	Def.	Max.
h0	PU	Programme version		-	-	-
	Pr	Programme revision		-	-	-
	bU	Bootloader version		-	-	-
	br	Bootloader revision		-	-	-
	PRr	Parameter map revision		-	-	-
	PCr	PCr Valor CRC del programa		-	-	-
	bCr	CRC value of the bootloader		-	-	-
	EP	Exit to level 1				

*Not valid for AKO-575744 / AKO-575744N / AKO-575744NE

Default parameters

To set the device to factory default, switch off the power supply and switch it on again, press the sequence ▲, ▼ and SET within 2 minutes.

The display shows the message dFP (default parameters) with a choice of two options:

0: Parameters are not modified

1: All parameters are reset to their default values.

Connectivity

The transmitters are equipped with a port for connection of RS485 (MODBUS) data, which allows for remote management of these using a AKO-5010, AKO-5025, AKO-5041 or AKO-5051 gateway. The MODBUS address is factory-set and is indicated on the rating plate located on the left side of the transmitter. This address must be different for each unit within the same network. The address can be changed using parameter b20. Once modified, the old address indicated on the plate will not be valid.

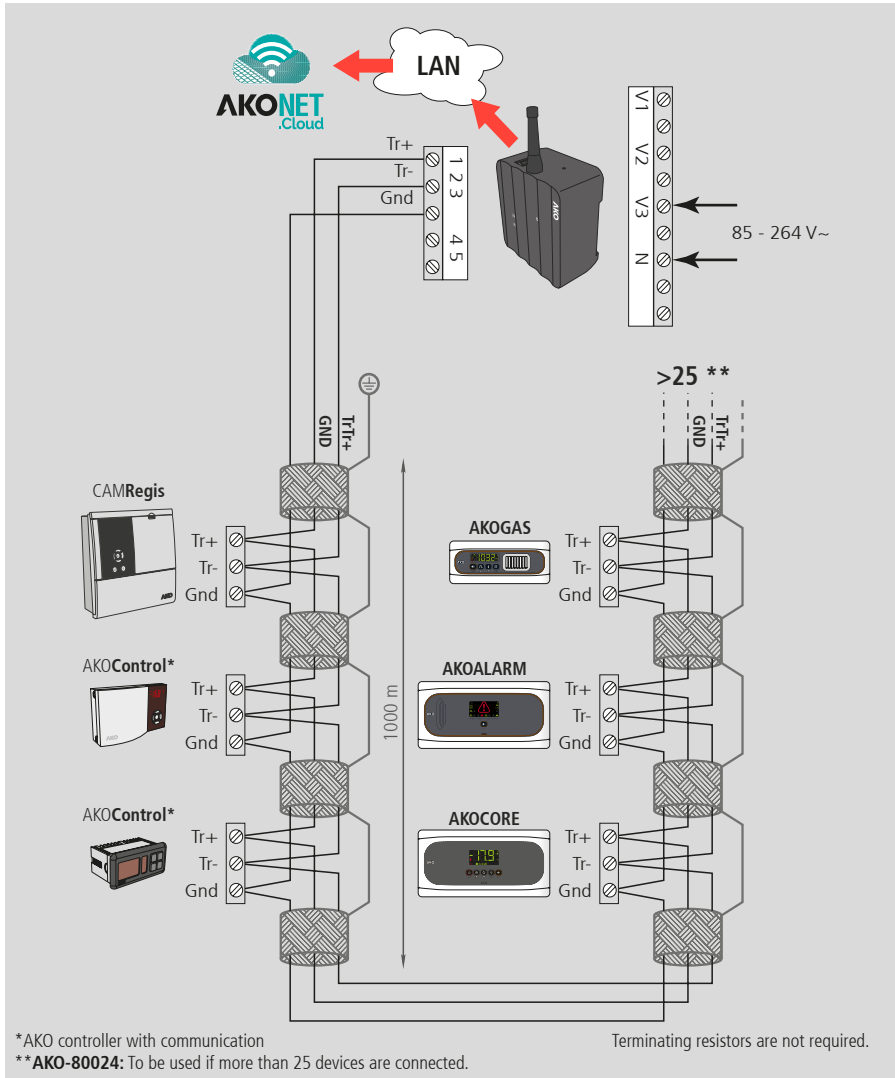

8.- Maintenance

- Clean surface of unit gently with soft cloth lightly soaked in water only
- Do not use abrasive detergents, petrol, alcohol or solvents, as this might damage the sensor.

9.- Installation of AKO-58110 calibration kit

The **AKO-58110** calibration kit enables the testing, verification of accuracy, reset to zero and calibration of the transmitter. These tasks will be explained in the following pages.

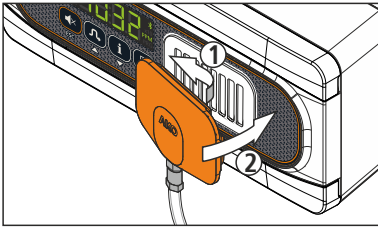

Install the kit, attaching it to the transmitter window as shown in the image.

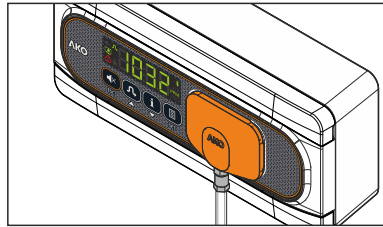

Press hard until it fits together perfectly.

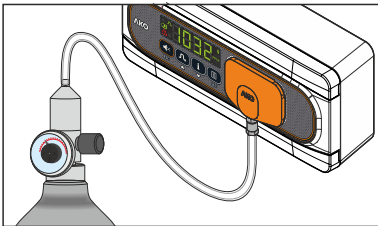

Connect the regulator of the gas pump to the free end of the transparent tube.

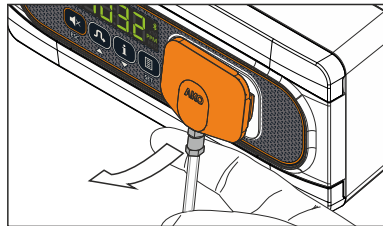

To extract it, pull out from the lower end.

10.- Operation test (Bump Test)

Materials required: AKO-58110 calibration kit
Cylinder of refrigerant gas diluted in air (< 2000 ppm)*

International standards require verification of the correct operation of the transmitter at least once per year. Please check what current local regulations specify for such cases.

Always ensure that you comply with current local regulations.

- Before starting the verification procedure, check the Pre-Alarm configuration (**AL2**). This should be enabled in order to check it has been activated. It is advisable to disable the Pre-Alarm delay (**AL5**) and Alarm delay (**AL8**) to speed up the verification process.
- Install the **AKO-58110** calibration kit following the instructions on page 18.
- Open the shut-off valve of the gas cylinder and wait.
- After a few moments, the transmitter concentration reading will begin to rise until it reaches the Pre-Alarm and then Alarm level.
- Check that both the Pre-Alarm and the Alarm signal correctly and that the corresponding relays are activated.
- Close the shut-off valve of the gas cylinder, disconnect the cylinder and remove the calibration kit from the transmitter.



The transmitter may take a few moments to go back to showing the concentration values from before the verification procedure.

Once the verification procedure is complete, remember to readjust the Pre-Alarm (**AL2**) and delay (**AL5** and **AL8**) parameters to the values prior to the beginning of the verification procedure.

*Use a cylinder with a type of gas that is suitable to the sensitivity of the transmitter to be calibrated.

11.- Verification of accuracy (Calibration)

Materials required: AKO-58110 calibration kit
Cylinder of refrigerant gas diluted in air (< 2000 ppm)*



AKO recommends verifying the accuracy of the transmitter at least once per year. Please check what current local regulations specify for such cases.

Always ensure that you comply with current local regulations.

- Install the **AKO-58110** calibration kit following the instructions on page 18.
- Open the shut-off valve of the gas cylinder and wait.
- After a few moments, the transmitter concentration reading will begin to rise. Wait for the reading to stabilise.
- Compare the reading displayed with the calibrated value of the gas cylinder. If the accuracy is sufficient for the intended application, it is not necessary to carry out a calibration. If the opposite is true, calibrate the transmitter following the instructions set out on page 22.
- Close the shut-off valve of the gas cylinder, disconnect the cylinder and remove the calibration kit from the transmitter.



The transmitter may take a few moments to go back to showing the concentration values from before the verification procedure.

*Use a cylinder with a type of gas that is suitable to the sensitivity of the transmitter to be calibrated.

12.- Reset to zero

OPTION A: CLEAN AIR (Not valid for AKO-575744 / AKO-575744N / AKO-575744NE)

- Before beginning the reset to zero procedure, ensure that the area of the premises is **free of freon gas** and any other substances that could affect the transmitter, and that the transmitter **has been operating for at least 20 minutes**.
- Enter the programming menu by pressing the **SET** key for 10 seconds and access section **1 n0**, parameter **1 00** (see page 14). The unit will request a confirmation code (**cod**). Use keys **▼** and **▲** to enter code 63 and press **SET**.
- Use keys **▼** and **▲** to select option 1 and press **SET**. This will start the process.
- During the process, the display will alternate between showing the gas concentration and the **CRl** message and the illuminated  symbol. This process will last for between 30 seconds and 5 minutes. On completion, if the reset to zero process has been successful, the display will show "End" and emit a long beep.

OPTION B: WITH NITROGEN GAS (Not valid for AKO-575744 / AKO-575744N / AKO-575744NE)

Materials required: AKO-58110 calibration kit
 Nitrogen gas cylinder

- After initiating the reset to zero process, ensure that the transmitter **has been operating for at least 20 minutes**.
- Install the **AKO-58110** calibration kit following the instructions on page 18.
- Enter the programming menu by pressing the **SET** key for 10 seconds and access section **1 n0**, parameter **1 00** (see page 14). The unit will request a confirmation code (**cod**). Use keys **▼** and **▲** to enter code 63 and press **SET**.
- Use keys **▼** and **▲** to select option 1 and press **SET**. This will start the process.
- Open the shut-off valve of the gas cylinder and wait.
- During the process, the display will alternate between showing the gas concentration and the **CRl** message and the  symbol illuminated. This process will last for between 30 seconds and 5 minutes. On completion, if the reset to zero process has been successful, the display will show "End" and emit a long beep.
- Close the shut-off valve of the nitrogen gas cylinder, disconnect the cylinder and remove the calibration kit from the transmitter.



If any problems have been detected during the reset to zero process, the transmitter will emit three short beeps and display one of the following error codes:

CODE	ERROR
EC	A reading of greater than 300 PPM has been detected during the process.
Et	The temperature of the sensor has experienced a variation of greater than 5 °C.
Eto	The maximum time period (5 min) has been exceeded and the reading has not stabilised.

13.- Full scale setting

(Not valid for AKO-575744 / AKO-575744N / AKO-575744NE)

Materials required: **AKO-58110** calibration kit
Cylinder of refrigerant gas diluted in air (< 2000 ppm)*



Check whether current local regulations require a specific calibration frequency. **Always ensure that you comply with current local regulations.**

- After initiating the calibration process, ensure that the transmitter **has been operating for at least 20 minutes.**
- Reset the transmitter to zero following the instructions on page 21.
- Install the **AKO-58110** calibration kit following the instructions on page 18.
- Press the **SET** key for 10 seconds to enter the programming menu.
- When calibrating an **AKO-575400**, **AKO-575400N** or **AKO-57400NE** universal transmitter, configure parameter **Gc2** to **RLL**.
- Access section **1 n0**, parameter **1 0 1**. The unit will request a confirmation code (**Code**). Use keys **▼** and **▲** to enter code 63 and press **SET**.
- Use keys **▼** and **▲** to select option 1 and press **SET**. This will start the process.
- Open the shut-off valve of the gas cylinder and wait.
- During the process, the display will alternate between showing the gas concentration and the **ERL** message and the illuminated  symbol. This process will last for up to 15 minutes. On completion, if the calibration process has been successful, the display will show "**End**" and emit a long beep.
- Close the shut-off valve of the nitrogen gas cylinder, disconnect the cylinder and remove the calibration kit from the transmitter.



If any problems have been detected during the calibration process, the transmitter will emit three short beeps and show one of the following error codes:

CODE	ERROR
Et	The temperature of the sensor has experienced a variation of greater than 5°C.
Eto	The maximum time period (15 min) has been exceeded and the reading has not stabilised.



The transmitter may take a few moments to go back to showing the concentration values from before the calibration procedure.

AKO-575400 / 575400N / 57400NE only: Once the verification procedure has been completed, remember to adjust parameter **Gc2** to the value prior to the start of the calibration procedure.



The maintenance mode automatically activates for 5 minutes to prevent activation of alarms after calibration has finished.

In this case, the maintenance mode cannot be manually deactivated.

* Use a cylinder with a type of gas that is suitable to the sensitivity of the transmitter to be calibrated. To set model **AKO-575400**, **AKO-575400N** or **AKO-57400NE**, set parameter **Gc2** to **134A** and use a cylinder of refrigerant gas **R134a** diluted in air at 2000 ppm.

14.- Technical specifications

Power supply.....	12 - 30 Vdc
Consumption	Typical..... 75 mA
	Maximum..... 125 mA
Pre-Alarm/Alarm relay	SPDT 30 Vdc 2 A, 30 Vac 2A cos φ=1
Working ambient temperature	AKO-575744 / N / NE.....-40 °C to 50 °C
	Other models.....-30 °C to 50 °C
Storage ambient temperature	AKO-575744 / N / NE.....-40 °C to 60 °C
	Other models.....-30 °C to 60 °C
Range of maximum moisture permitted	0 - 95 % HR (without condensation)
Protection degree.....	IP 68
IP rating has not been evaluated by UL	
Type of sensor	NDIR (Non-Dispersive Infrared Technology)
Display range	AKO-575744 / N / NE..... 0 - 10000 x1 ppm
	Other models
Estimated working life.....	5 years
Dimensions	202 mm (W) x 82 (H) x 55.5 mm (D)

Only NB-IoT devices

Bands NB-IoT (Narrow band) LTE Cat NB1 | B2, B3, B4, B8, B12, B13, B20

Band	Frequency Rx	Frequency Tx
2	1930 MHz ~ 1990 MHz.....	1850 MHz ~ 1910 MHz
3	1805 MHz ~ 1880 MHz.....	1710 MHz ~ 1785 MHz
4	2110 MHz ~ 2155 MHz.....	1710 MHz ~ 1755 MHz
8	925 MHz ~ 960 MHz.....	880 MHz ~ 915 MHz
12	729 MHz ~ 746 MHz.....	699 MHz ~ 716 MHz
13	746 MHz ~ 756 MHz.....	777 MHz ~ 787 MHz
20	791 MHz ~ 821 MHz.....	832 MHz ~ 862 MHz

Maximum transmission power	23.5 dBm conducted
Antenna	AKO-575400NE, AKO-575744NE..... External
	Other models..... Internal
Use.....	Indoor use

Sensor specifications:

		AKO-575400N/NE (Universal)	AKO-575744N/NE (CO ₂)
Precision -40 °C to -30 °C	400 - 5000 ppm	-	5%
	5000 - 10000 ppm	-	10%
Precision -30 °C to -20 °C		See table	7%
Precision -20 °C to 45 °C			3%
Precision 45 °C to 50 °C		2	7%
Level of concentration detectable (PPM)	Minimum	20	20
	Maximum	2000	10000
Alarm levels (PPM)*	Inferior	500	4000
	Greater	1000	8000
Alarm response time (seconds)**		60	
Full scale response time (seconds)		180	
Recovery time (seconds)		300	
Working life (years)		5	
Recommended verification frequency (years)***		1	

The precision values indicated are valid if the transmitter is reset to zero once installed in its definitive location and with the planned working temperature.

Table 2: AKO-575400 / 575400N / 575400NE transmitter measurement error

		Measurement error based on parameter Gc2 configuration												
		R-134a	R-404A	R-407A	R-410A	R-125	R-448A	R-449A	R-407F	R-513A	R-452A	R-32	R-23	R-455A
Temp.	-30 °C to -20 °C / 45 °C to 50	6%	10%	8%	10%	10%	12%	12%	12%	11%	13%	13%	13%	13%
	-20 °C to 45 °C	4%	7%	5%	7%	7%	10%	10%	10%	8%	10%	10%	10%	10%
		Measurement error if Gc2 = ALL												
		R-125 / R-134A / R-404A / R-407A / R-407F / R-410A / R-448A / R-449A						R-513A / R-452A / R-32 / R-23 / R-455A / R-450A / R-442A / R-454A / R-454c / R-1234yf / R-1234ze / R515b****						
Temp	-30 °C to 50 °C	32%						35%						

* Alarm levels are customisable. The values are shown by default and are acceptable for complying with all local and international regulations covering the safety of individuals. These values can be excessive for detecting small leaks.

** The response time was indicated for an alarm level at 1000 PPM. The time depends on the alarm value set by the user.

*** It is necessary to use a calibrated gas when carrying out the verification procedure.

**** **R-515b**: To reduce the measurement error to 20%, select R-513A in parameter Gc2.

15.- Accessories

Herramienta de calibración para transmisores AKO-58110

This enables testing (Bump Test), verification of accuracy, reset to zero and field calibration of **AKO-575xxx** gas transmitters.

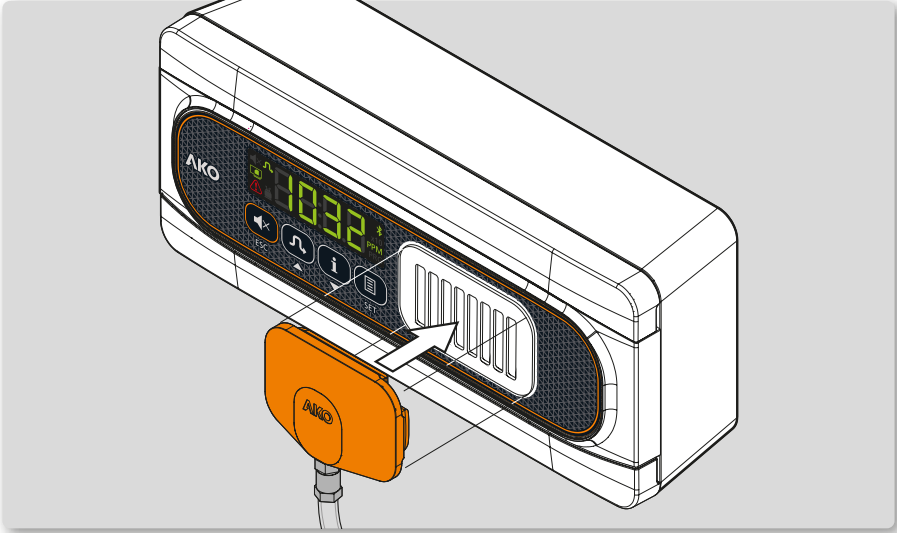

Protector AKO-58120

Protects the AKO-575xxx gas transmitter against possible knocks.

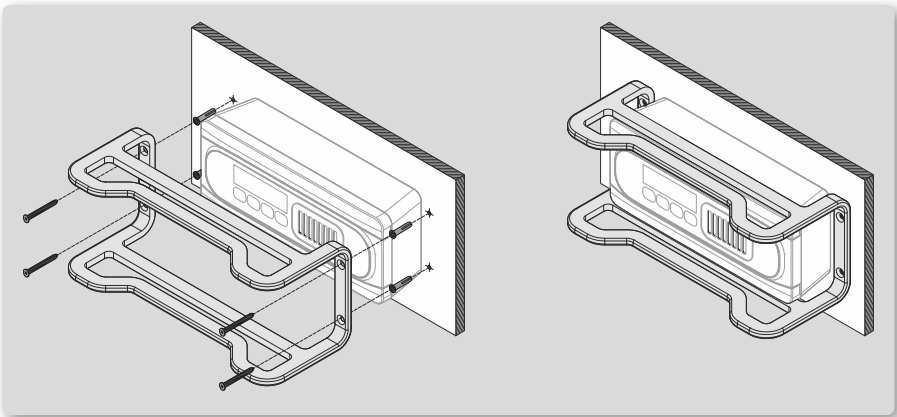

AKO-58500 CAMM Module

Together with the application for mobile devices, this module provides the unit with multiple functionalities:

- Data logging
- Logging of configuration changes
- Remote configuration
- Clock functions in real time
- Activity summaries
- Logging of events and alerts
- Remote control of functions

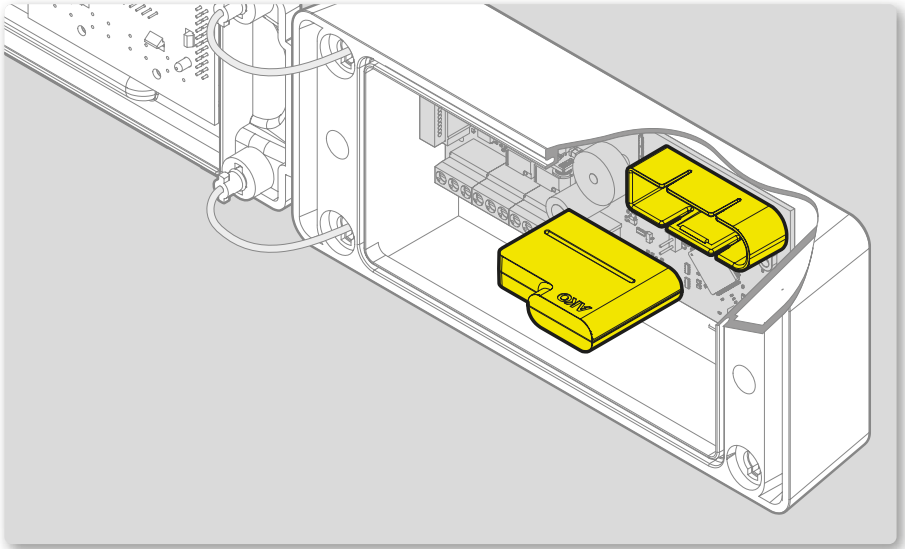

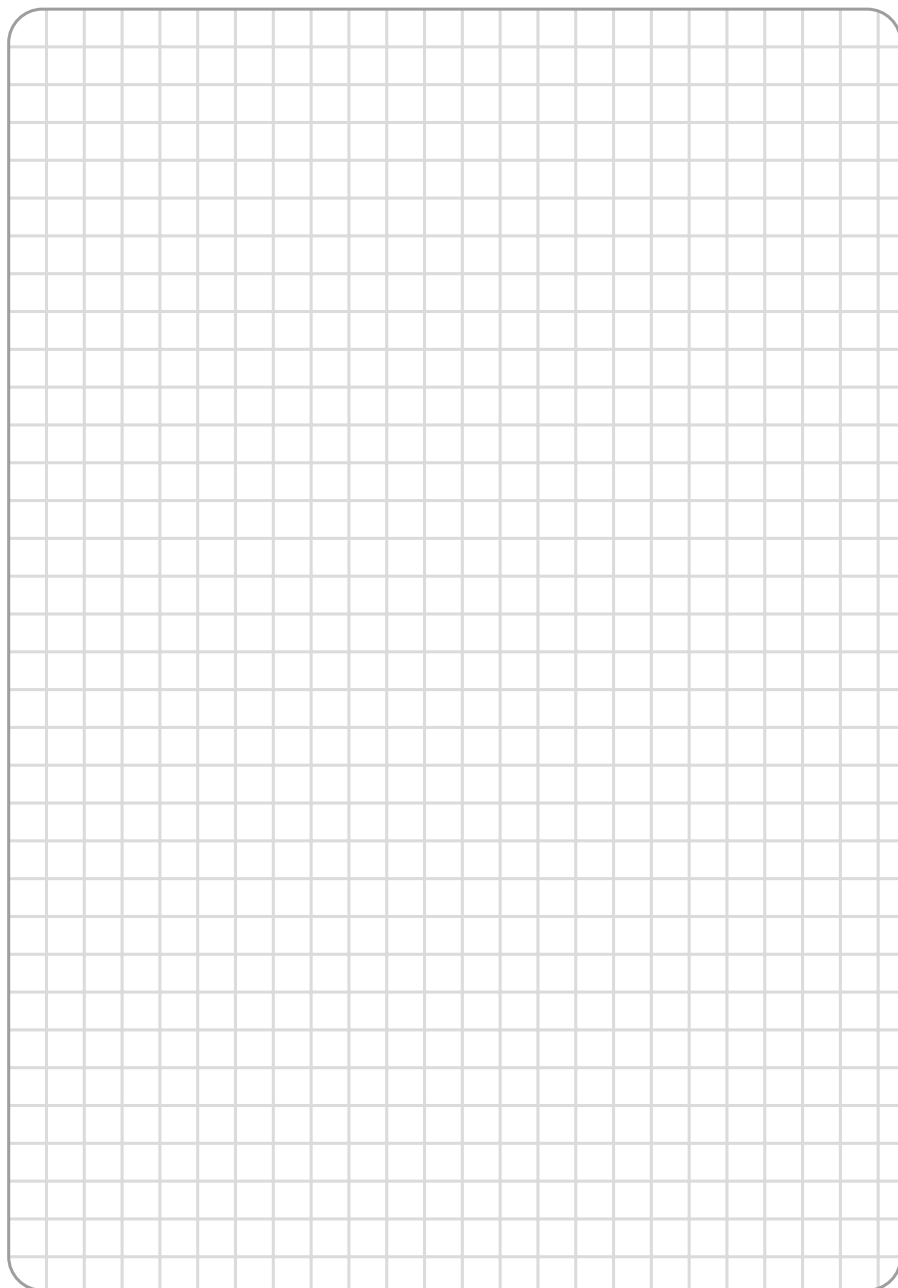

AKO ELECTROMECÁNICA , S.A.

Avda. Roquetes, 30-38
08812 • Sant Pere de Ribes.
Barcelona • Spain

www.ako.com

355753102 Rev. 00 2025